

# Postup výstavby Metra I.D v úseku Pankrác–Olbrachtova

Ing. Jaromír Heřt



**SUBTERRA** 



# Postup výstavby Metra I.D v úseku Pankrác–Olbrachtova

## Členění projektu

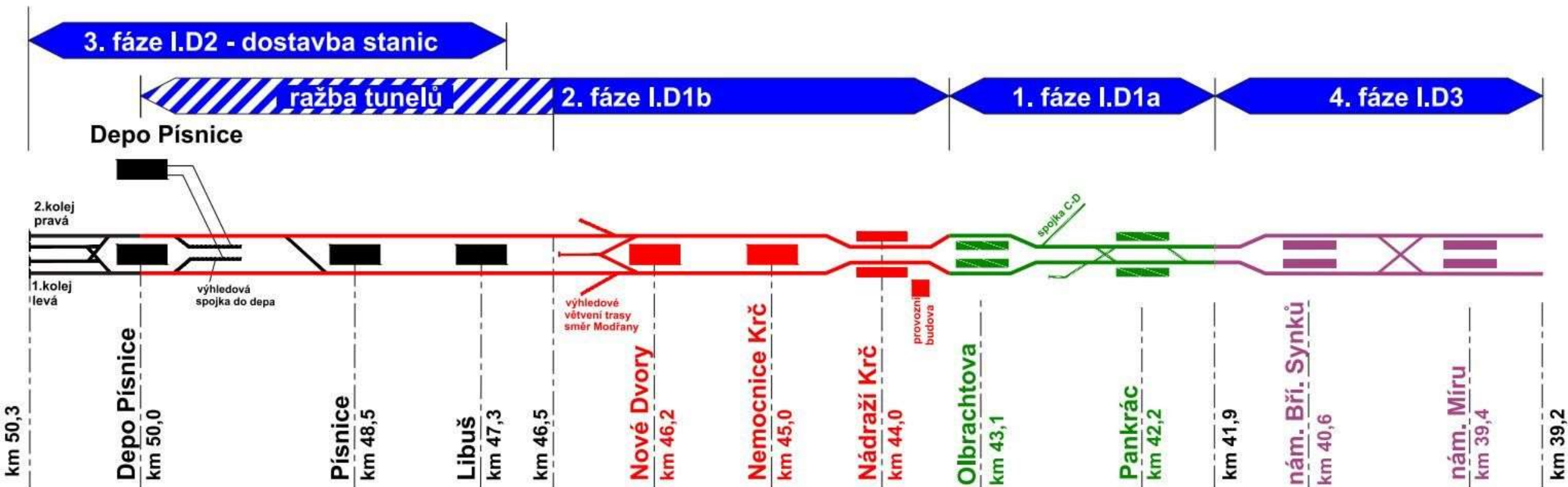

# Postup výstavby Metra I.D v úseku Pankrác–Olbrachtova

## Základní technické údaje 1. fáze I.D1a

celková délka trasy (včetně stanic) 1 286 m

2 nové stanice

**jednolodní stanice Pankrác D s bočními nástupišti  
a s přestupní chodbou**

- ražená stanice (NRTM)
- přestup na metro C
- ostatní podzemní objekty

**dvoulodní stanice Olbrachtova**

- ražená stanice (NRTM)
- ostatní podzemní objekty

**traťový úsek**

- jednokolejné a dvoukolejné tunely (NRTM)
- C-D spojka (NRTM)
- ostatní podzemní objekty

**související objekty**

- hloubené jámy
- přeložky IS, sanace mostního objektu a případné sanace ostatních nadzemních objektů



# Postup výstavby Metra I.D v úseku Pankrác–Olbrachtova

situace stavby

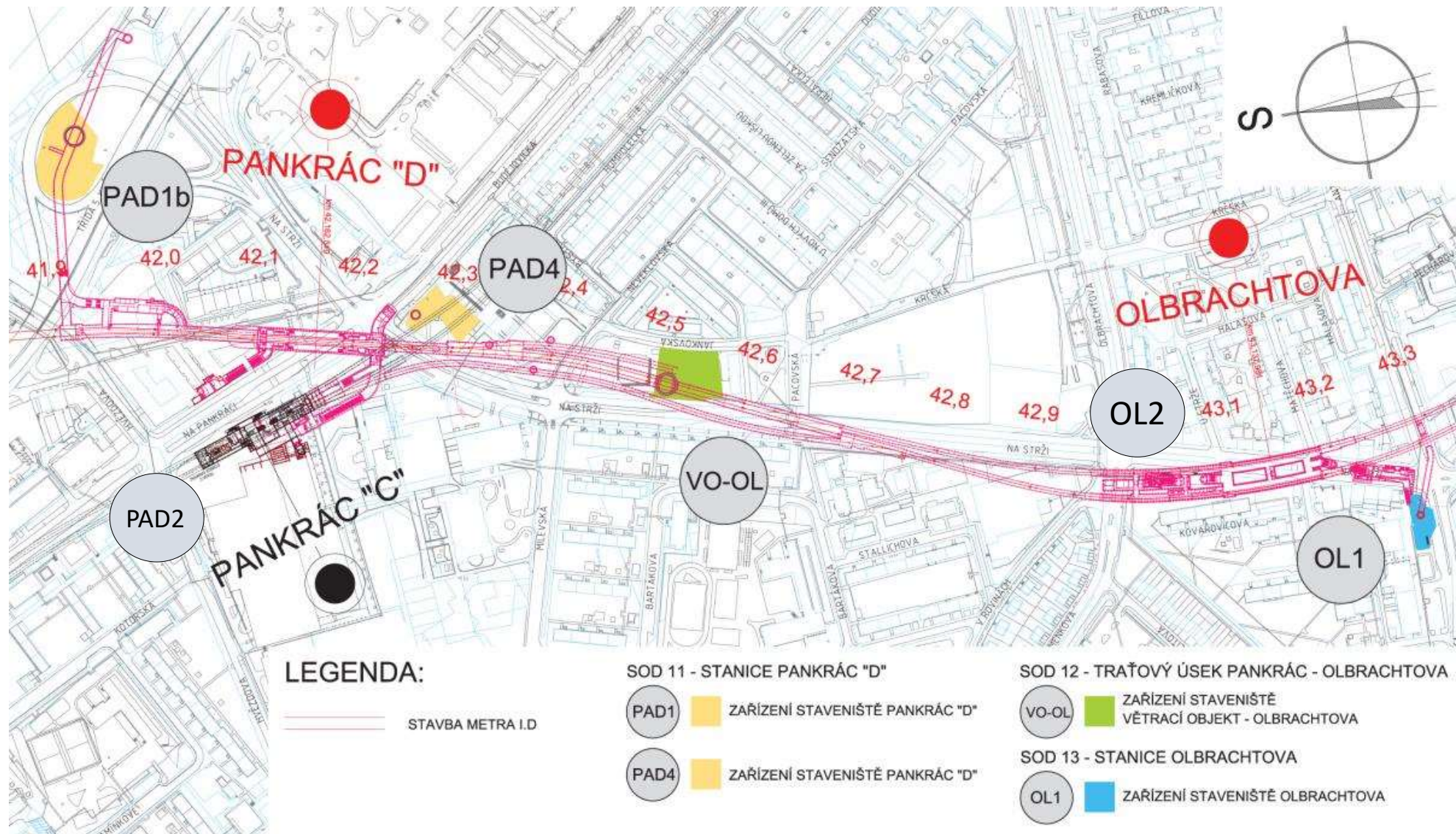

# Postup výstavby Metra I.D v úseku Pankrác–Olbrachtova

situace stavby

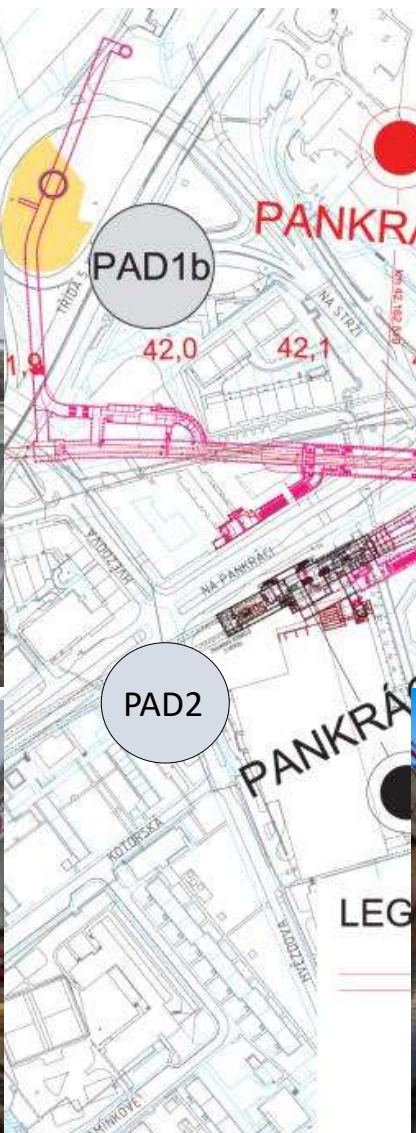

# Postup výstavby Metra I.D v úseku Pankrác–Olbrachtova

## úsek Pankrác–Olbrachtova

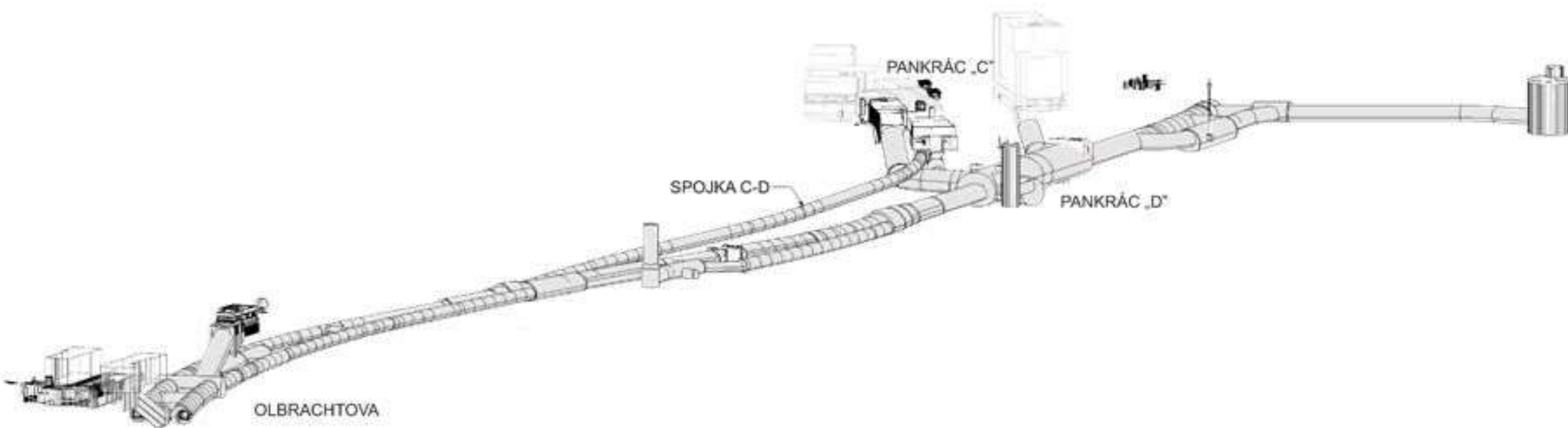



# Postup výstavby Metra I.D v úseku Pankrác–Olbrachtova

## SOD 11 stanice Pankrác

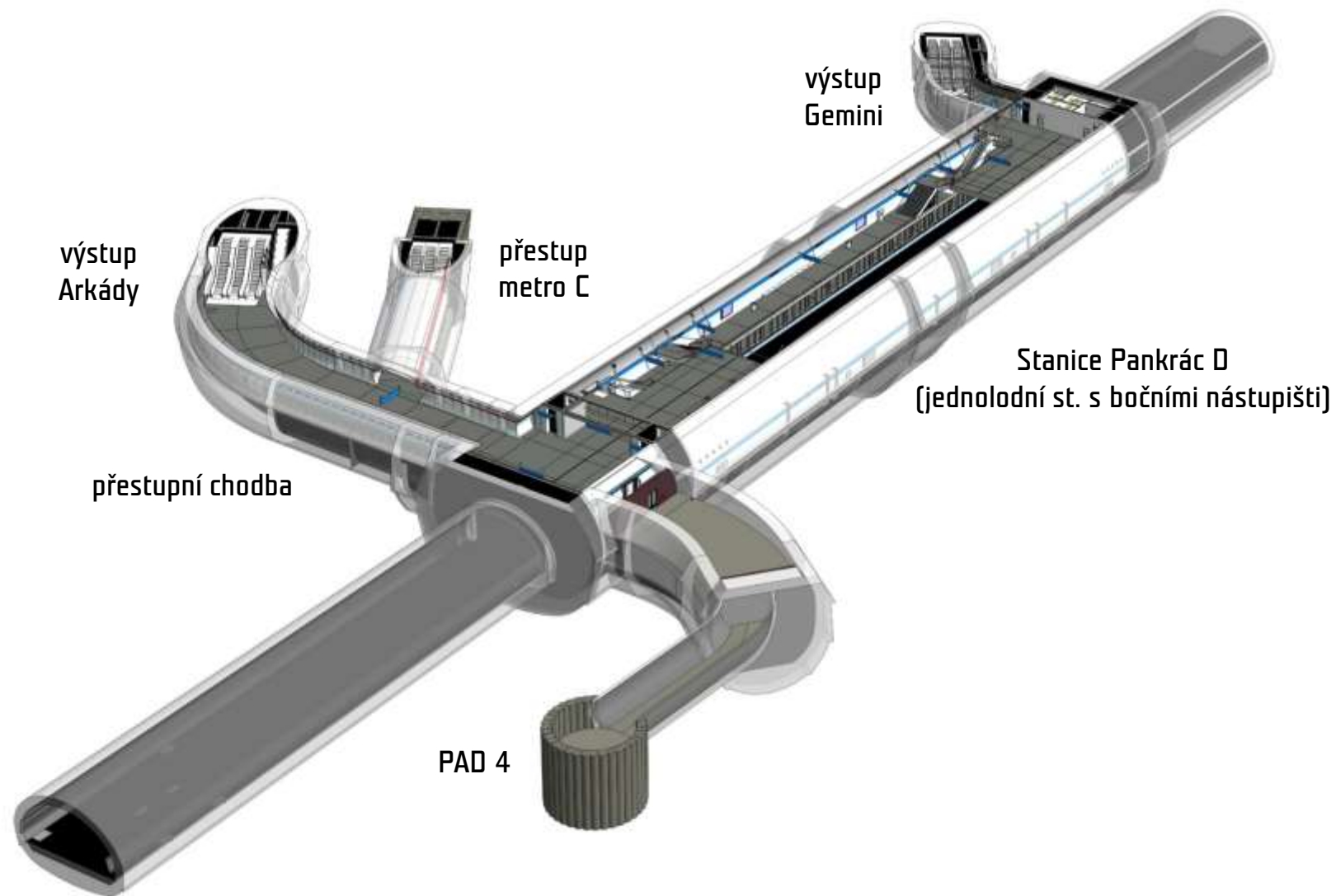

# Postup výstavby Metra I.D v úseku Pankrác–Olbrachtova

SOD 11 stanice  
Pankrác

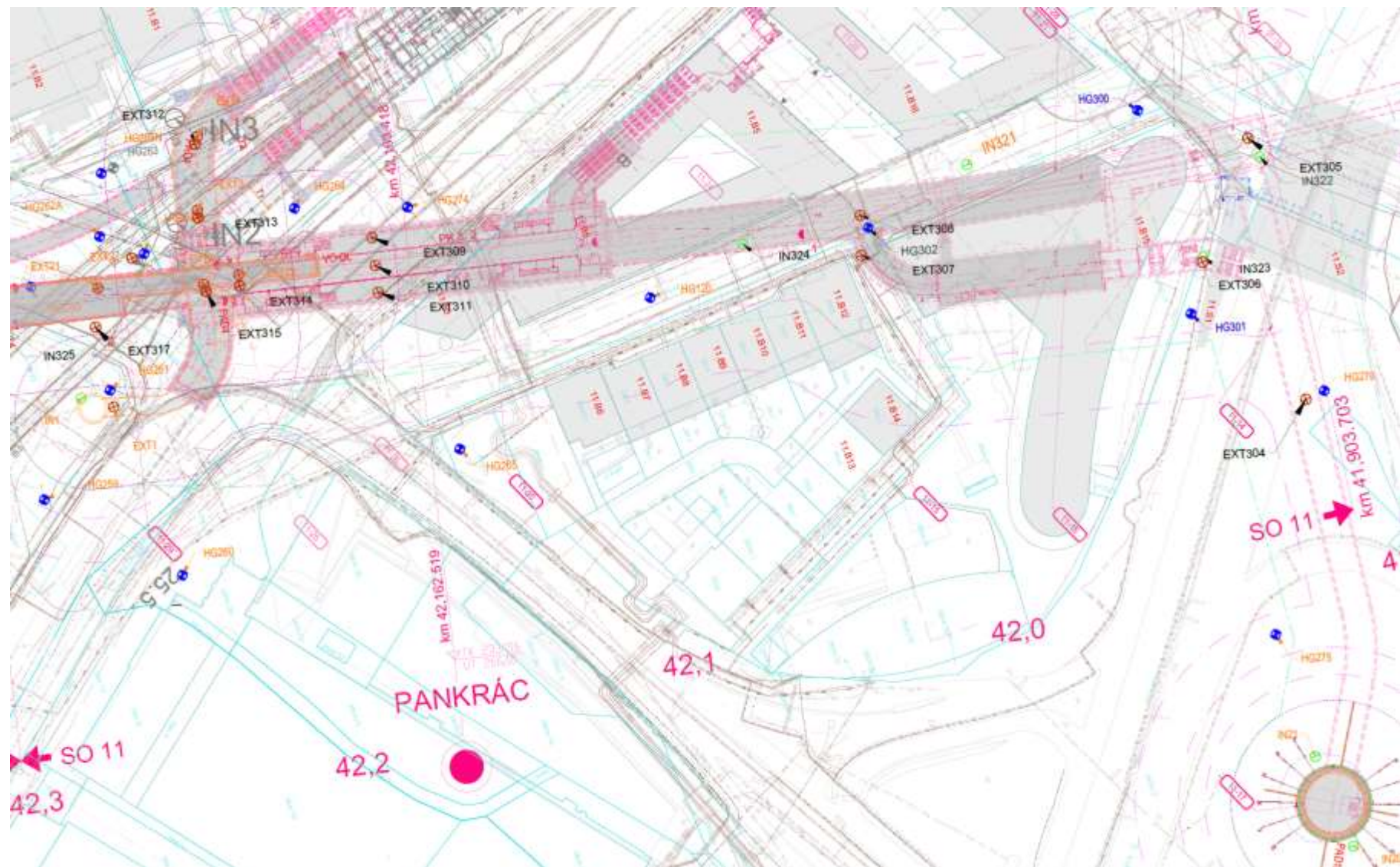

# Postup výstavby Metra I.D v úseku Pankrác–Olbrachtova



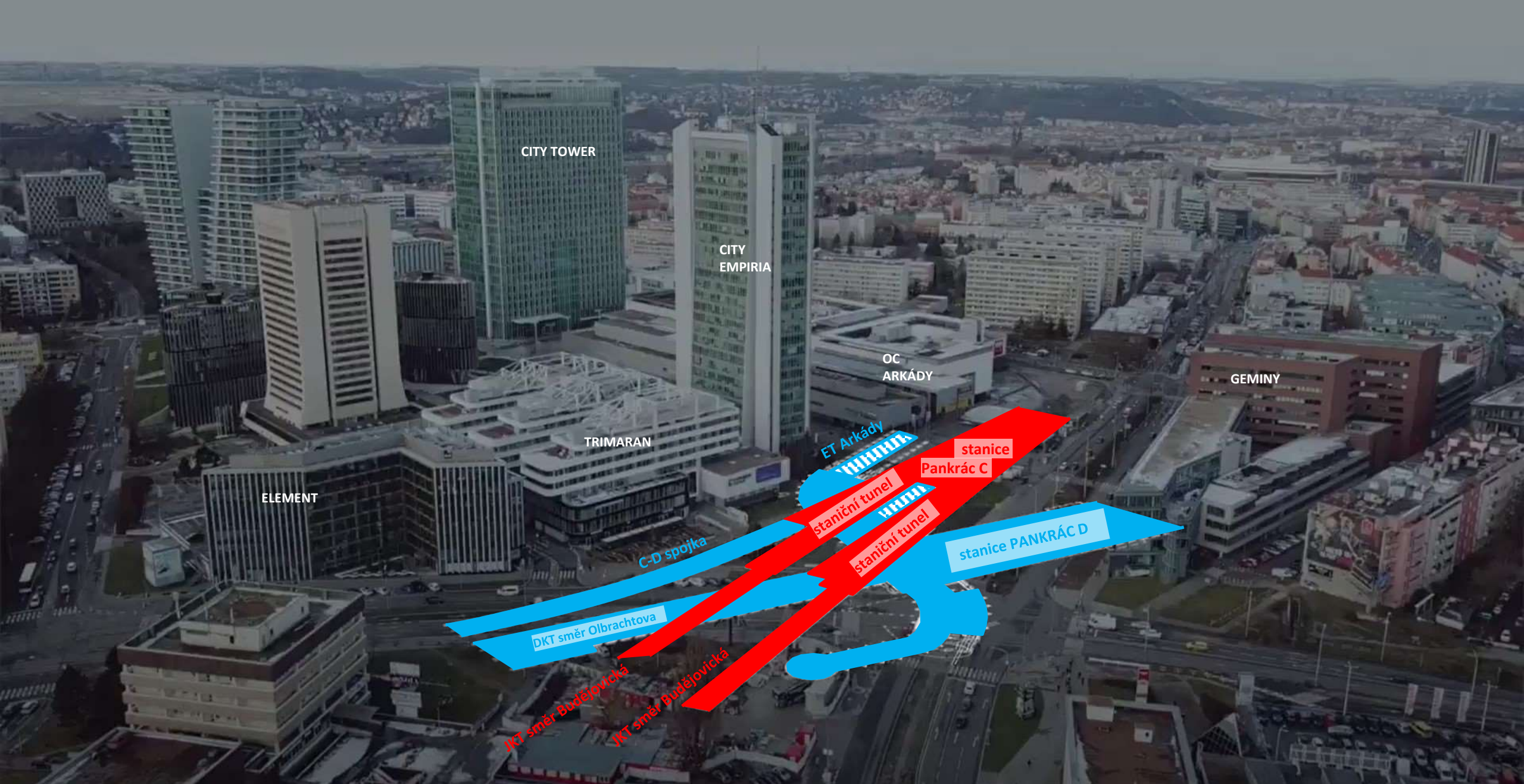

CITY TOWER

CITY EMPIRIA

OC ARKÁDY

GEMINY

TRIMARAN

ELEMENT

ET Arkády

stanice Pankrác C

stanice PANKRÁC D

staniční tunel

staniční tunel

C-D spojka

DKT směr Olbrachtova

DKT směr Budějovická

DKT směr Budějovická



# Postup výstavby Metra I.D v úseku Pankrác–Olbrachtova

## SOD 12 traťový úsek PA-OL

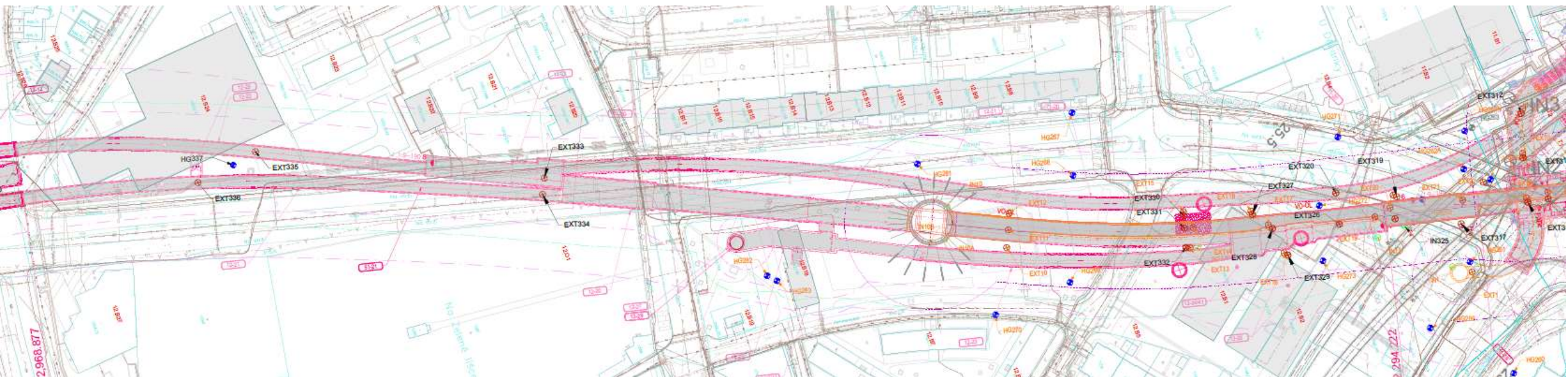

# Postup výstavby Metra I.D v úseku Pankrác–Olbrachtova

## SOD 12 traťový úsek PA-OL (k 1Q/23)

SO 12-22 Rozplet do C-D spojky  
SO 12-22 Pravý jednok. tunel

IGP  
Těžní šachta  
Dílčí výrub Dvoukolejného tunelu

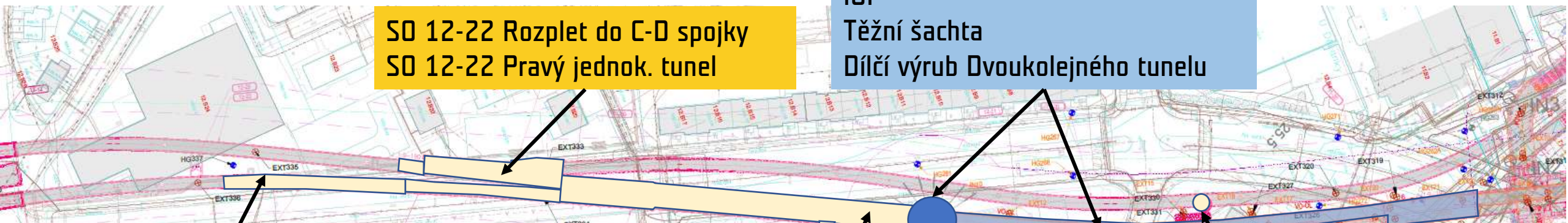

VZT stola



# Postup výstavby Metra I.D v úseku Pankrác–Olbrachtova

## SOD 13 stanice Olbrachtova

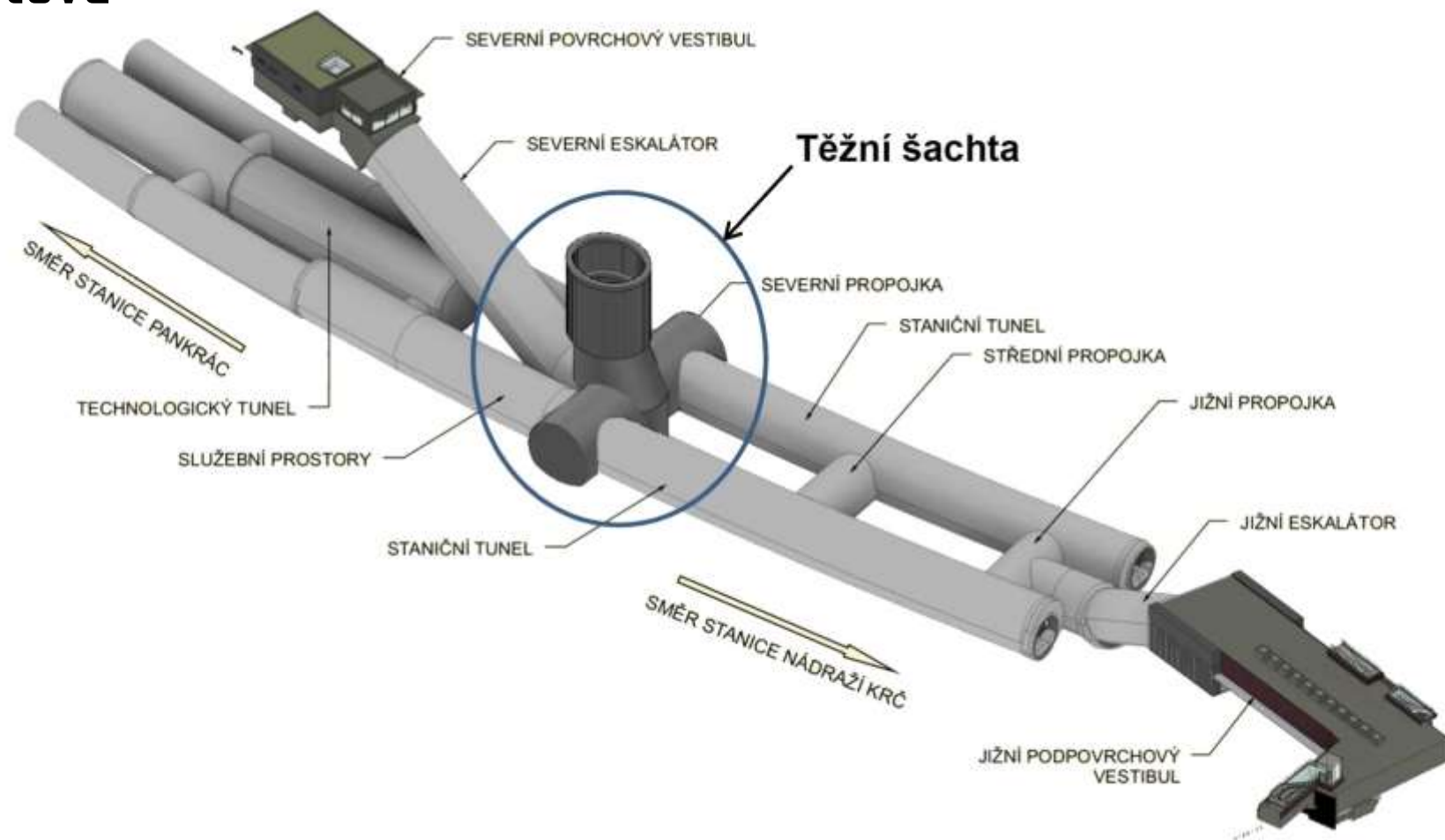

# Postup výstavby Metra I.D v úseku Pankrác–Olbrachtova

## SOD 13 stanice Olbrachtova

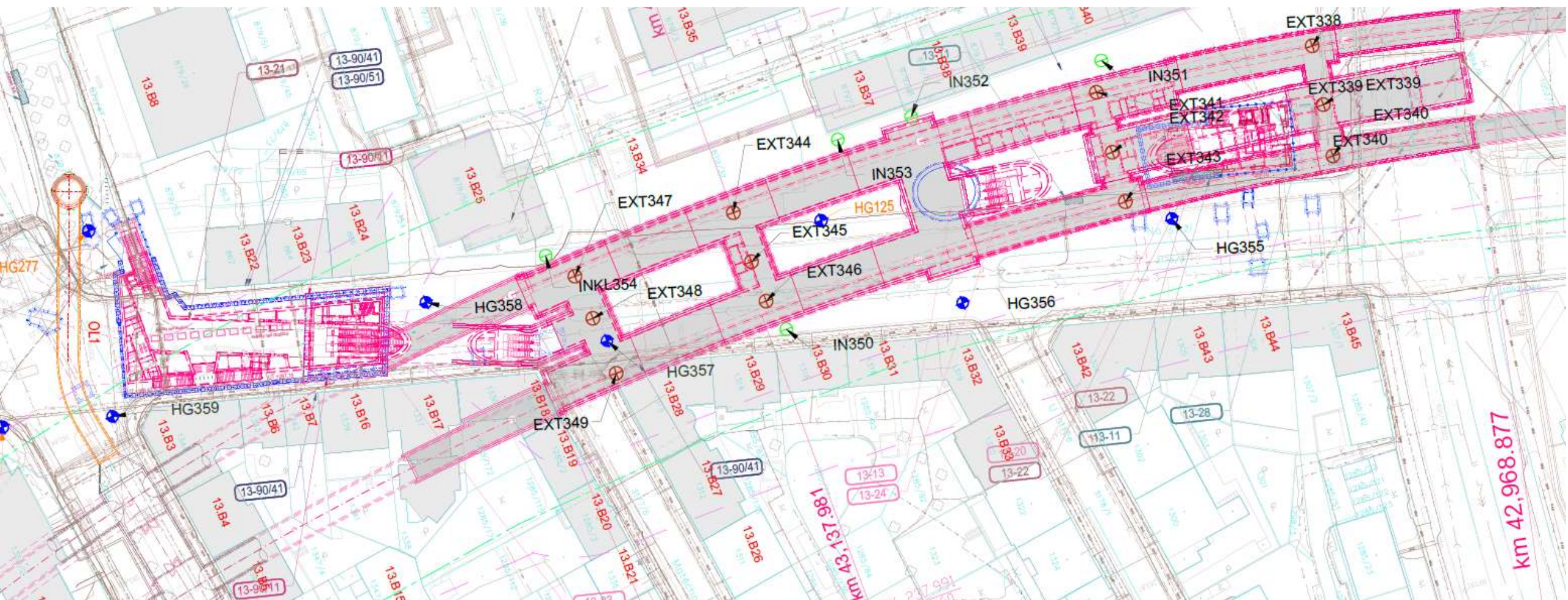



# Postup výstavby Metra I.D v úseku Pankrác–Olbrachtova

## SOD 13 stanice Olbrachtova (k Q1/23)

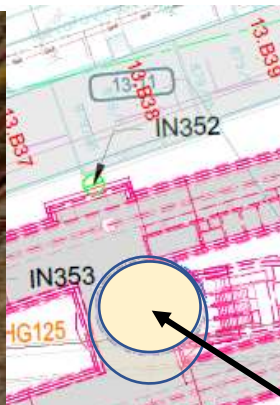



	METRO I.D1a ražby [ m ]	METRO I.D1a hloubení [ m ]	METRO I.D1a realizace [ m3 ]	METRO I.D1a 100% [ m3 ]	METRO I.D1a rubanina [ % ]
S00 11 Stanice Pankrác	403,00	0,00	23 058,00	133 600,00	17,3%
S00 12 Traťový úsek	534,30	79,00	40 900,00	75 000,00	54,5%
S00 13 Stanice Olbrachtova	0,00	20,50	3 890,00	85 400,00	4,6%



